

Stone Concept

5 COLOURS

4 SIZES

3 SURFACES

A collection inspired by white Burgundy stone; a sedimentary rock, which can take on various aspects, because it includes delicate colour patches and veins.

Una collezione che si ispira alla pietra di borgogna bianca; una roccia calcarea sedimentaria, che può assumere varie apparenze, perché include delicate macchie di colore e vene.

Diese Kollektion ist am weißen Burgunderstein inspiriert, einem Kalkstein, der mit seinen zarten Farbflecken und Äderungen unterschiedliche Ausprägungen annehmen kann.

Une collection inspirée de la pierre blanche de Bourgogne: une roche sédimentaire calcaire qui peut avoir plusieurs aspects en raison de ses délicates taches colorées et veines.

Stone Concept



Spazi Residenziali
Residential Spaces

P. 5

Spazi Pubblici
Public Areas

P. 21

Informazioni Tecniche
Technical Information

P. 37

Questa pietra è utilizzata da secoli sia per il rivestimento murale dei nobili castelli francesi che per la loro pavimentazione, e proprio dalla pavimentazione di un castello nella valle della Loira è stata recuperata la particolare pietra a cui si ispira “Stone Concept”, rendendo il design di questa serie assolutamente esclusivo ed irripetibile.

This stone has been used for centuries both for the wall coverings of noble French castles and for their paving, and it is from the paving of a castle in the Loire Valley that the particular stone which inspired “Stone Concept” was recovered, making the design of this series absolutely exclusive and unrepeatable.

Dieser Stein wird seit Jahrhunderten als Wand- und Bodenbelag in französischen Schlössern verwendet, und aus dem Bodenbelag eines Schlosses im Loire-Tal stammt jener besondere Stein, an dem sich „Stone Concept“ inspiriert. Das macht das Design dieser Serie so einzigartig und unnachahmlich.

Cette pierre est utilisée depuis des siècles pour habiller les murs et les sols des splendides châteaux français, et c'est précisément dans un château de La Loire, sur son sol pour l'exactitude, qu'a été récupérée la pierre spéciale dont s'inspire « Stone Concept », une collection flanquée d'un style absolument exclusif et unique.

Spazi Residenziali

Residential Spaces
Wohnanlagen
Espaces Résidentiels



COLORI / COLOURS

AMBIENTI / AMBIENT

PAGINA / PAGE

Sabbia	Entrance	7
Sabbia	Living	8
Luce	Bathroom	12
Argento	Terrace	17

Stone Concept
Residential Spaces

5

Sabbia

Sober nuances, legible veins, and soft colour variations enhance the singularity of a timeless collection, inspired by the stones recovered from old dwellings.

Einfache Nuancen, deutliche Äderungen und zarte Farbvariationen unterstreichen die Einzigartigkeit einer zeitlosen Kollektion, die alte Steine aus historischen Anwesen zum Vorbild hat.

Les délicates nuances, les veines apparentes et les légères variantes de couleurs exaltent la singularité d'une collection atemporelle qui puise son inspiration dans les pierres des demeures anciennes.

Sobrie sfumature, venature leggibili, e tenui variazioni cromatiche esaltano l'unicità di una collezione senza tempo, ispirata alle pietre recuperate da antiche dimore.

30x60 - 12"x24" Levigato Rettificato



Stone Concept
Residential Spaces



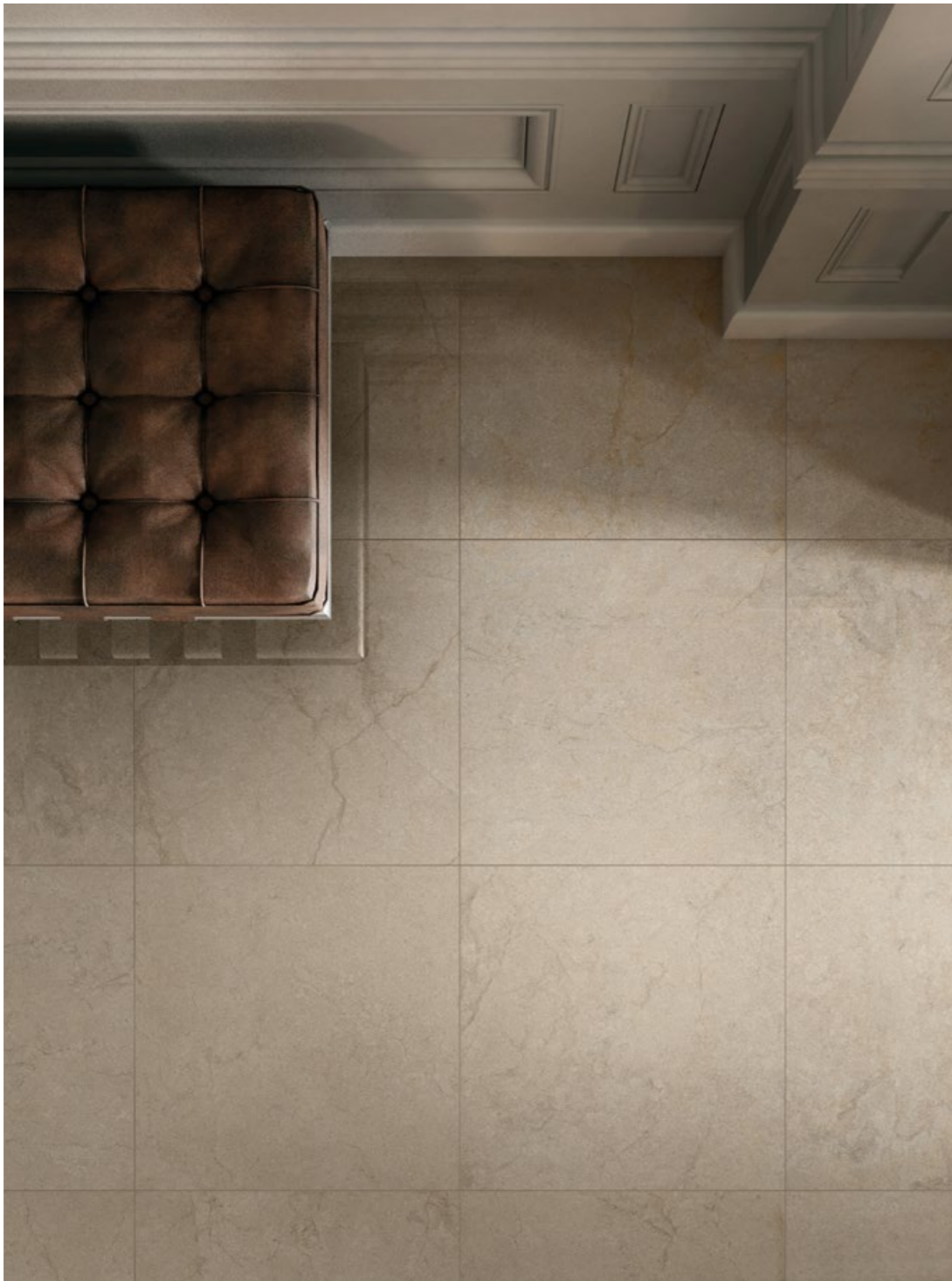





Argento

The outdoor slabs with bush-hammered finish ensure strong adherence and their natural look reinterprets the qualities of stone materials.

Die Platten für Außenverkleidungen mit gekrönelter Oberfläche garantieren gute Haftung und zeichnen sich durch ein natürliches Aussehen aus, das die Besonderheit des Steinmaterials neu interpretiert.

Les dalles d'extérieur, avec finition bouchardée, garantissent une très grande adhérence et affichent un aspect naturel incarnant toutes les valeurs de la pierre.

Le lastre per esterno con finitura bocciardata garantiscono requisiti di elevata aderenza e propongono un aspetto naturale che reinterpreta le qualità dei materiali lapidei.

80×80 - 31½"×31½" Bocciardato Rettificato



Stone Concept
Residential Spaces



Spazi Pubblici

Public Areas
 Öffentliche Räumlichkeiten
 Espaces Publics



COLORI / COLOURS

AMBIENTI / AMBIENT

PAGINA / PAGE

Grigio	Food Court	22
Grigio / Argento	Public Outdoor	25
Sabbia	Museum	28
Bianco / Argento	Bathroom	33

Grigio

Elegant and forever contemporary colours dress environments, including public and commercial ones, where polished surfaces juxtaposed with natural ones enhance floor depths and spaces.

Elegante und stets aktuelle Farben kleiden die Räume auch in öffentlichen und gewerblichen Bereichen, wo polierte Oberflächen im Mix mit naturbelassenen Flächen die Tiefe unterstreichen und die Räume dekorieren.

Les espaces publics et commerciaux se parent de colorations élégantes et sans cesse contemporaines. Les finitions polies côtoient les surfaces naturelles pour donner plus de profondeur et pour embellir les espaces.

Cromatismi eleganti e sempre contemporanei rivestono gli ambienti anche nell'ambito pubblico e commerciale, dove superfici levigate, giustapposte a superfici naturali, esaltano la profondità dei piani arricchendo gli spazi.

60x119,5 - 24"x47½" Levigato Rettificato

29x59 - 11½"x23¼" Brick Mix Rettificato



Stone Concept
Public Areas



Grigio / Argento

The appeal of stone transposed onto ceramic material at the service of contemporary architecture.

Die auf Keramik übertragene Magie des Natursteins im Dienst der zeitgenössischen Architektur.

Le charme de la pierre transposée sur céramique au service de l'architecture contemporaine.

Il fascino della pietra trasposto sul materiale ceramico a servizio dell'architettura contemporanea.

80x80 - 31½"x31½" Bocciardato Rettificato

60x119,5 - 24"x47½" Naturale Rettificato



Stone Concept
Public Areas





Bianco / Argento

The slabs support the project in numerous ways, thanks to the wide range enhanced by 3D structures and different sizes.

Die Platten bereichern das Projekt in vielen Kontexten dank des reichen Sortiments, das auch 3D-Strukturen und unterschiedliche Formate umfasst.

La richesse de la gamme, assortie de structures 3D et différents formats, permet d'utiliser les dalles dans des nombreux projets.

Le lastre sono in grado di supportare il progetto in molteplici contesti, grazie all'ampiezza della gamma arricchita da strutture 3D e differenti formati.

30×60 - 12"×24" Lines Naturale Rettificato

30×60 - 12"×24" Naturale Rettificato



Stone Concept
Public Areas



Informazioni Tecniche

5

Colori
Colours
Farben
Couleurs

Luce



Bianco



Sabbia



Argento

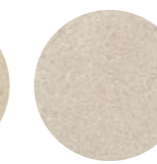

Grigio

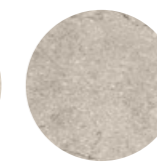

4

Formati
Sizes
Formate
Formats

*60×119,5
24"×47½"



80×80
31½"×31½"



60×60
24"×24"



30×60
12"×24"



*formato modulare con 60x60 e 30x60 / modular size, can be matched with 60x60 and 30x60 size /
modulares, spricht mit dem Format 60x60 und 30x60 kombinierbares Format / format modulaire pouvant être coordonné au format 60x60 et 30x60

2

Spessori
Thickness
Stärke
Epaisseur

±9,5

±10,5

3

Superfici
Surfaces
Oberflächen
Surfaces

Naturale

Levigato

Bocciardato

2

Strutture 3D
3D structures
Strukturen
Décorations en relief

Weave



Slant



i

Effetto Pietra
Stone Look
Natursteinoptik
Effet Pierre

Rivestimento
Wall Tiles
Wandfliesen
Revêtement

Pavimento
Floor Tiles
Bodenfliesen
Sol

Gres fine porcellanato
Fine porcelain stoneware
Feinsteinzeug
Grès cérame fin

Tecnologia digitale
Digital technology
Digital technologie
Technologie numérique



Luce



± 9,5

***60x119,5 - 24"x47 1/2"**
02506 | Stone Concept Luce Nat/Ret
02507 | Stone Concept Luce Lev/Ret

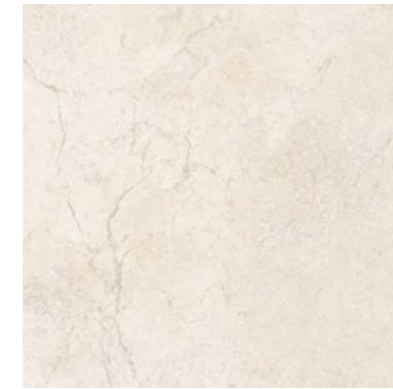

± 10,5

80x80 - 31 1/2"x31 1/2"
02511 | Stone Concept Luce Nat/Ret
02512 | Stone Concept Luce Lev/Ret



± 10,5

80x80 - 31 1/2"x31 1/2"
02513 | Stone Concept Luce Bocciardato/Ret

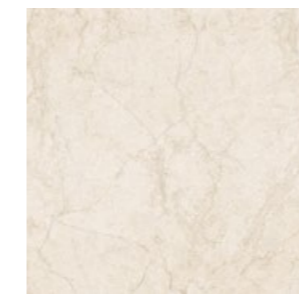

± 9,5

60x60 - 24"x24"
02504 | Stone Concept Luce Nat/Ret
02505 | Stone Concept Luce Lev/Ret



± 9,5

60x60 - 24"x24"
02509 | Stone Concept Slant Luce Ret

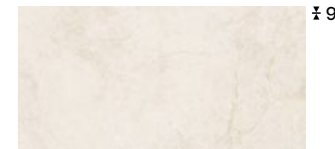

± 9,5

30x60 - 12"x24"
02501 | Stone Concept Luce Nat/Ret
02502 | Stone Concept Luce Lev/Ret



± 9,5

29x59 - 11 1/2"x23 1/2"
02514 | Stone Concept Brick Mix Luce Ret



± 9,5

30x60 - 12"x24"
02515 | Stone Concept Lines Luce Nat/Ret

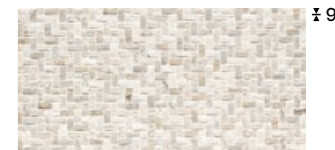

± 9,5

30x60 - 12"x24"
02503 | Stone Concept Weave Luce Ret

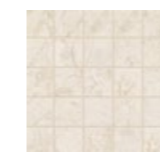

± 9,5

30x30 - 12"x12"
02524 | Stone Concept Mosaico Luce Nat/Ret

* formato modulare con 60x60 e 30x60 / modular size, can be matched with 60x60 and 30x60 size
modulares, spricht mit dem Format 60x60 und 30x60 kombinierbares Format / format modulaire pouvant être coordonné au format 60x60 et 30x60

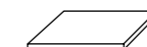
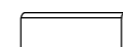



Bianco



± 9,5
*60x119,5 - 24"x47 1/2"
02227 | Stone Concept Bianco Nat/Ret
02232 | Stone Concept Bianco Lev/Ret



± 10,5
80x80 - 31 1/2"x31 1/2"
02242 | Stone Concept Bianco Nat/Ret
02246 | Stone Concept Bianco Lev/Ret



± 10,5
80x80 - 31 1/2"x31 1/2"
02313 | Stone Concept Bianco Bocciardato/Ret

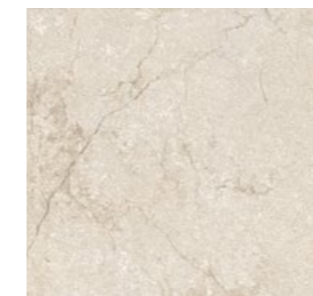

± 9,5
60x60 - 24"x24"
02218 | Stone Concept Bianco Nat/Ret
02223 | Stone Concept Bianco Lev/Ret



± 9,5
60x60 - 24"x24"
02305 | Stone Concept Slant Bianco Ret

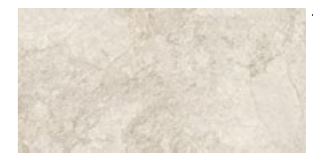

± 9,5
30x60 - 12"x24"
02201 | Stone Concept Bianco Nat/Ret
02205 | Stone Concept Bianco Lev/Ret



± 9,5
29x59 - 11 1/2"x23 1/4"
02325 | Stone Concept Brick Mix Bianco Ret



± 9,5
30x60 - 12"x24"
02331 | Stone Concept Lines Bianco Nat/Ret



± 9,5
30x60 - 12"x24"
02209 | Stone Concept Weave Bianco Ret

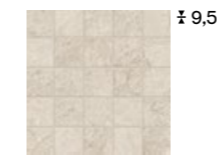

± 9,5
30x30 - 12"x12"
02496 | Stone Concept Mosaico Bianco Nat/Ret

* formato modulare con 60x60 e 30x60 / modular size, can be matched with 60x60 and 30x60 size
modulares, spricht mit dem Format 60x60 und 30x60 kombinierbares Format / format modulaire pouvant être coordonné au format 60x60 et 30x60

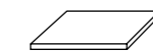
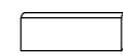



Sabbia

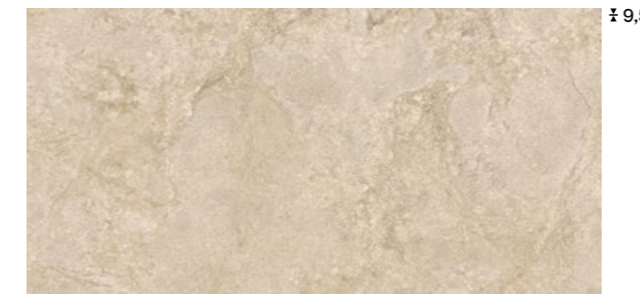

*60x119,5 - 24"x47 1/2"
02228 | Stone Concept Sabbia Nat/Ret
02233 | Stone Concept Sabbia Lev/Ret



80x80 - 31 1/2"x31 1/2"
02243 | Stone Concept Sabbia Nat/Ret
02247 | Stone Concept Sabbia Lev/Ret

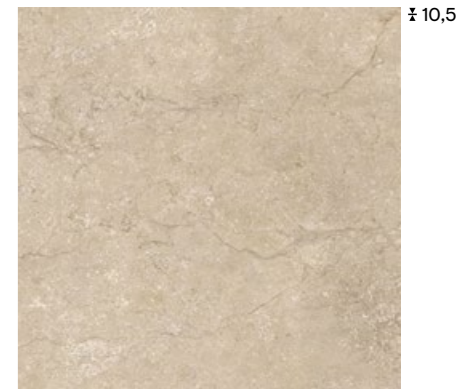

80x80 - 31 1/2"x31 1/2"
02314 | Stone Concept Sabbia Bocciardato/Ret

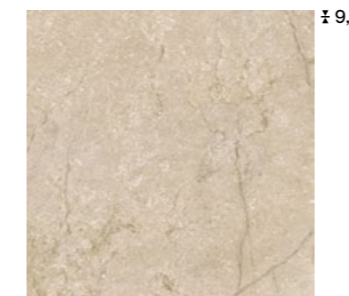

60x60 - 24"x24"
02219 | Stone Concept Sabbia Nat/Ret
02224 | Stone Concept Sabbia Lev/Ret



60x60 - 24"x24"
02306 | Stone Concept Slant Sabbia Ret

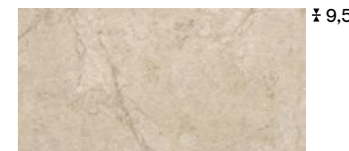

30x60 - 12"x24"
02202 | Stone Concept Sabbia Nat/Ret
02206 | Stone Concept Sabbia Lev/Ret



29x59 - 11 1/2"x23 1/4"
02326 | Stone Concept Brick Mix Sabbia Ret



30x60 - 12"x24"
02332 | Stone Concept Lines Sabbia Nat/Ret

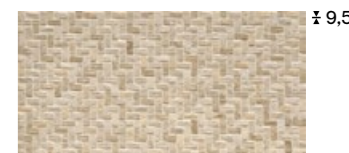

30x60 - 12"x24"
02211 | Stone Concept Weave Sabbia Ret

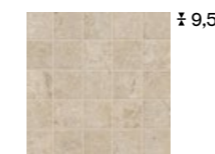

30x30 - 12"x12"
02497 | Stone Concept Mosaico Sabbia Nat/Ret

* formato modulare con 60x60 e 30x60 / modular size, can be matched with 60x60 and 30x60 size
modulares, spricht mit dem Format 60x60 und 30x60 kombinierbares Format / format modulaire pouvant être coordonné au format 60x60 et 30x60



Argento



*60x119,5 - 24"x47½"
02229 | Stone Concept Argento Nat/Ret
02234 | Stone Concept Argento Lev/Ret



80x80 - 31½"x31½"
02244 | Stone Concept Argento Nat/Ret
02248 | Stone Concept Argento Lev/Ret



80x80 - 31½"x31½"
02315 | Stone Concept Argento Bocciardato/Ret

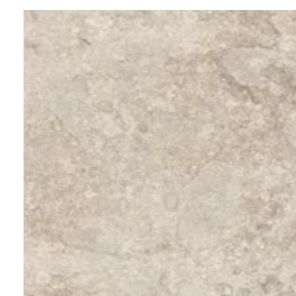

60x60 - 24"x24"
02221 | Stone Concept Argento Nat/Ret
02225 | Stone Concept Argento Lev/Ret



60x60 - 24"x24"
02307 | Stone Concept Slant Argento Ret

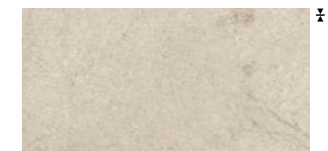

30x60 - 12"x24"
02203 | Stone Concept Argento Nat/Ret
02207 | Stone Concept Argento Lev/Ret



29x59 - 11½"x23¼"
02327 | Stone Concept Brick Mix Argento Ret



30x60 - 12"x24"
02333 | Stone Concept Lines Argento Nat/Ret



30x60 - 12"x24"
02212 | Stone Concept Weave Argento Ret

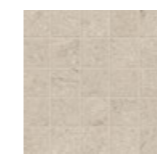

30x30 - 12"x12"
02498 | Stone Concept Mosaico Argento Nat/Ret

* formato modulare con 60x60 e 30x60 / modular size, can be matched with 60x60 and 30x60 size
modulares, spricht mit dem Format 60x60 und 30x60 kombinierbares Format / format modulaire pouvant être coordonné au format 60x60 et 30x60



Grigio



*60x119,5 - 24"x47½"
02231 | Stone Concept Grigio Nat/Ret
02235 | Stone Concept Grigio Lev/Ret



80x80 - 31½"x31½"
02245 | Stone Concept Grigio Nat/Ret
02249 | Stone Concept Grigio Lev/Ret



80x80 - 31½"x31½"
02316 | Stone Concept Grigio Bocciardato/Ret

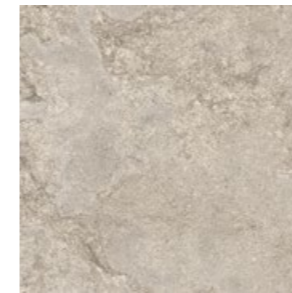

60x60 - 24"x24"
02222 | Stone Concept Grigio Nat/Ret
02226 | Stone Concept Grigio Lev/Ret



60x60 - 24"x24"
02308 | Stone Concept Slant Grigio Ret



30x60 - 12"x24"
02204 | Stone Concept Grigio Nat/Ret
02208 | Stone Concept Grigio Lev/Ret



29x59 - 11½"x23½"
02328 | Stone Concept Brick Mix Grigio Ret



30x60 - 12"x24"
02334 | Stone Concept Lines Grigio Nat/Ret

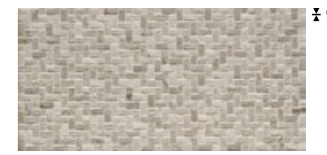

30x60 - 12"x24"
02213 | Stone Concept Weave Grigio Ret

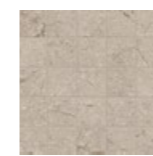

30x30 - 12"x12"
02499 | Stone Concept Mosaico Grigio Nat/Ret

* formato modulare con 60x60 e 30x60 / modular size, can be matched with 60x60 and 30x60 size
modulares, spricht mit dem Format 60x60 und 30x60 kombinierbares Format / format modulaire pouvant être coordonné au format 60x60 et 30x60

Fasce di Prezzo

- Fascia prezzo al metro quadro
Square meter price range
Quadratmeter preisgruppe
Niveau de prix au mètre carré
- ▲ Fascia prezzo al pezzo
Price range per piece
Stück preisgruppe
Niveau de prix à la piece

Price range
Preisgruppe
Niveau de prix

Formati Sizes					Din 51130	Din 51097	Dcof			
	60x119,5 - 24"x47 1/2"	80x80 - 31 1/2"x31 1/2"	60x60 - 24"x24"	30x60 - 12"x24"						
	€ 9,5	€ 10,5	€ 9,5	€ 9,5						
Luce	Nat/Ret	02506 740	02511 740	02504 550	02501 500	V2	R10	A+B	>0.42	
	Lev/Ret	02507 790	02512 770	02505 680	02502 650					
	Bocciardato/Ret		02513 780				R11	A+B+C	>0.42	
Bianco	Nat/Ret	02227 740	02242 740	02218 550	02201 500	V2	R10	A+B	>0.42	
	Lev/Ret	02232 790	02246 770	02223 680	02205 650					
	Bocciardato/Ret		02313 780				R11	A+B+C	>0.42	
Sabbia	Nat/Ret	02228 740	02243 740	02219 550	02202 500	V2	R10	A+B	>0.42	
	Lev/Ret	02233 790	02247 770	02224 680	02206 650					
	Bocciardato/Ret		02314 780				R11	A+B+C	>0.42	
Argento	Nat/Ret	02229 740	02244 740	02221 550	02203 500	V2	R10	A+B	>0.42	
	Lev/Ret	02234 790	02248 770	02225 680	02207 650					
	Bocciardato/Ret		02315 780				R11	A+B+C	>0.42	
Grigio	Nat/Ret	02231 740	02245 740	02222 550	02204 500	V2	R10	A+B	>0.42	
	Lev/Ret	02235 790	02249 770	02226 680	02208 650					
	Bocciardato/Ret		02316 780				R11	A+B+C	>0.42	

Strutture 3D 3D Structures	
€ 9,5	€ 9,5
02509 680	02503 560
02305 680	02209 560
02306 680	02211 560
02307 680	02212 560
02308 680	02213 560

Fasce di Prezzo







- Fascia prezzo al metro quadro
Square meter price range
Quadratmeter preisgruppe
Niveau de prix au mètre carré
- ▲ Fascia prezzo al pezzo
Price range per piece
Stück preisgruppe
Niveau de prix à la piece

Price range
Preisgruppe
Niveau de prix

Formati Sizes									
	Lines 30x60 - 12"x24"	Brick Mix 29x59 - 11 1/2"x23 1/4"	Mosaico 30x30 - 12"x12"	Gradino 30x119,5 - 12"x47 1/4"	Gradino 30x60 - 12"x24"	Battiscopa 6,5x119,5 - 2 1/2"x47 1/4"	Battiscopa 8x80 - 3 1/4"x31 1/2"	Battiscopa 8x60 - 3 1/4"x24"	
	€ 9,5	€ 9,5	€ 9,5	€ 9,5	€ 9,5	€ 9,5	€ 10,5	€ 9,5	
Luce	Nat/Ret	02515 660	02514 710	02524 160	02523 710	02522 200	02518 130	02520 100	02516 60
	Lev/Ret				02519 170	02521 140	02517 130		
Bianco	Nat/Ret	02331 660	02325 710	02496 160	02358 710	02353 200	02343 130	02348 100	02337 60
	Lev/Ret				02396 170	02401 140	02391 130		
Sabbia	Nat/Ret	02332 660	02326 710	02497 160	02359 710	02354 200	02344 130	02349 100	02338 60
	Lev/Ret				02397 170	02402 140	02392 130		
Argento	Nat/Ret	02333 660	02327 710	02498 160	02361 710	02355 200	02345 130	02350 100	02339 60
	Lev/Ret				02398 170	02403 140	02393 130		
Grigio	Nat/Ret	02334 660	02328 710	02499 160	02362 710	02356 200	02346 130	02351 100	02341 60
	Lev/Ret				02399 170	02404 140	02394 130		

Imballi

Packing
Verpackung
Emballage

Formati Sizes		± MM	 Pezzi Scatola Pieces/Box Stck/Karton Carreaux/Boite	 Mq/Scatola Sqmt/Box Qm/Karton M2/Boite	 Kg/Scatola Kgs/Box Kg/Karton Kg/Boite	 Scatole/Paletta Boxes/Pallet Karton/Palette Boite/Palette	 Mq/Paletta Sqmt/Pallet Qm/Pallet M2/Palette	 Kg/Paletta Kgs/Pallet Kg/Pallet Kg/Palette	 Formato Paletta Size Pallet Format Pallet Dim. Palette
80×80 (31½"×31½") Nat/Ret - Lev/Ret - Bocc/Ret	P	10,5	2	1,280	31,50	40	51,20	1260	120x80x97
60×119,5 (24"×47½") Nat Ret	P	9,5	2	1,434	31,00	30	43,02	930	120x80x75
60×119,5 (24"×47½") Lev Ret	P	9,5	2	1,434	32,00	30	43,02	960	120x80x75
60×60 (24"×24") Nat/Ret	P	9,5	3	1,080	21,50	40	43,20	860	120x80x75
60×60 (24"×24") Lev/Ret	P	9,5	3	1,080	22,50	40	43,20	900	120x80x75
30×60 (12"×24") Nat/Ret	P	9,5	6	1,080	21,50	48	51,84	1032	120x80x75
30×60 (12"×24") Lev/Ret	P	9,5	6	1,080	22,50	48	51,84	1080	120x80x75
60×60 (24"×24") Slant Ret	P	9,5	3	1,080	21,50	40	43,20	860	120x80x75
30×60 (12"×24") Weave Ret	P	9,5	6	1,080	21,50	40	43,20	860	120x80x75
30×60 (12"×24") Lines Nat/Ret	P	9,5	4	0,720	14,30	21	15,12	300	120x80x75
29×59 - 11½"×23½" Brick Mix Ret	P	9,5	4	0,680	14,30	16	10,88	228	120x80x75
30×30 (12"×12") Mosaico Nat/Ret	P	9,5	5	0,450	8,50	60	-	-	-

Pezzi Speciali / Special Pieces

30×119,5 (12"×47½") Gradino Nat/Ret	P	9,5	3	1,080	20,50	20	-	-	-
30×60 (12"×24") Gradino Nat/Ret	P	9,5	6	1,080	21,50	36	-	-	-
6,5×119,5 (2½"×47½") Battiscopa Nat/Ret - Lev/Ret	P	9,5	8	0,621 m.l. 9,60	12,50	48	-	-	-
8×80 (3½"×31½") Battiscopa Nat/Ret - Lev/Ret	P	10,5	7	0,448 m.l. 5,60	11,00	65	-	-	-
8×60 (3¼"×24") Battiscopa Nat/Ret - Lev/Ret	P	9,5	10	0,480 m.l. 6,00	11,00	72	-	-	-

Pezzi Speciali

Special pieces
Formstücke
Pièces spéciales

Battiscopa Nat/Ret 8×60 - 3½"×24" ± 9,5
Battiscopa Lev/Ret 8×60 - 3½"×24" ± 9,5

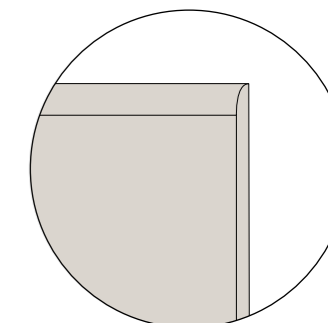
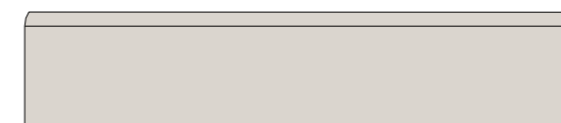

Battiscopa Nat/Ret 8×80 - 3½"×31½" ± 10,5
Battiscopa Lev/Ret 8×80 - 3½"×31½" ± 10,5

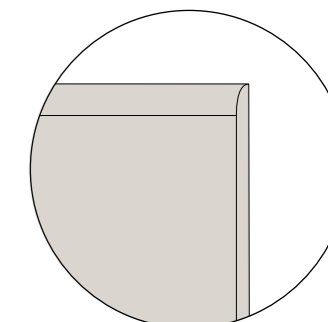
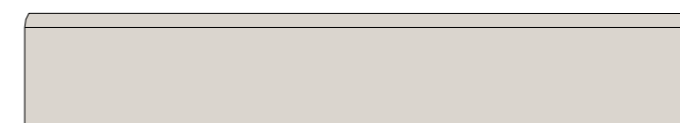

Battiscopa Nat/Ret 6,5×119,5 - 2½"×47½" ± 9,5
Battiscopa Lev/Ret 6,5×119,5 - 2½"×47½" ± 9,5

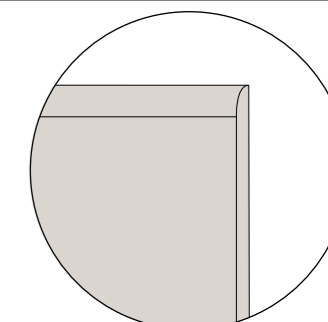

Gradino Nat/Ret 30×60 - 12"×24" ± 9,5
(Becco civetta e fresature tecniche - bullnose edge with grooves)

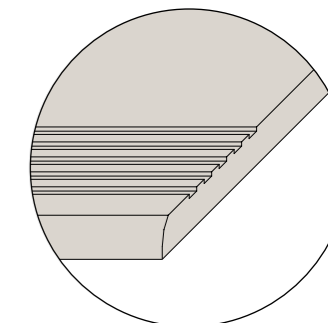

Gradino Nat/Ret 30×119,5 - 12"×47½" ± 9,5
(becco civetta tecnico - bullnose edge)

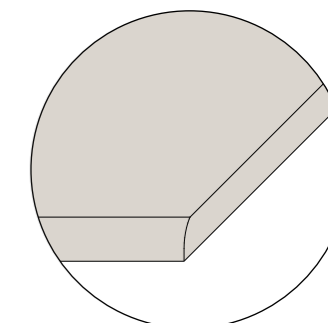

Caratteristiche Tecniche

Technical characteristics
Technische daten
Caracteristiques techniques

CLASSIFICAZIONE SECONDO NORME CEN/ISO GRUPPO B1A EN 14411 - ISO 13006 - CLASSIFICATION IN ACCORDANCE WITH CEN/ISO STANDARDS B1A EN 14411 - ISO 13006
KLASSIFIZIERUNG GEMÄSS CEN/ISO-NORMEN GRUPPE B1A EN 14411 - ISO 13006 - CLASSIFICATION SELON LES NORMES CEN/ISO GROUPE B1A EN 14411 - ISO 13006

CARATTERISTICA TECNICA TECHNICAL CHARACTERISTIC TECHNISCHE DATE CARACTÉRISTIQUE TECHNIQUE	NORMA NORM NORME	VALORE PRESCRITTO VALUE REQUIRED NORMVORGABE VALEUR PRESCRIPTE	VALORE MEDIO MEAN VALUE MITTELWERT VALEUR MOYENNE CERAMICHEPIEMME FLOOR AND MORE	USA TESTS 	VALORE MEDIO MEAN VALUE MITTELWERT VALEUR MOYENNE CERAMICHEPIEMME FLOOR AND MORE
LUNGHEZZA E LARGHEZZA LENGHT AND WIDTH / LANGE UND BREITE / LONGUEUR ET LARGEUR		±0,6% (±2,00 MM)			
SPESORE THICKNESS / STÄRKE / EPAISSEUR		±5% (±0,5 MM)			
RETILINEITÀ LATI WARPAGES OF EDGES / GERADHEIT DER KANTEN / RÉCTITUDE DES ARÊTES	ISO 10545.2	±0,5% (±15 MM)	CONFORME IN ACCORDANCE ERFÜLLT CONFORME	ASTM C-499 ASTM C-485 ASTM C-502	IN ACCORDANCE
ORTOGONALITÀ WEDGING / RECHTWINKLIGKEIT / ORTHOGONALITÉ		±0,5% (±2,00 MM)			
PLANARITÀ FLATNESS / PLANITÄT / PLANIMÉTRIE		±0,5% (±2,00 MM)			
ASSORBIMENTO % D'ACQUA WATER ABSORPTION WASSERANNAHME % ABSORPTION D'EAU %	ISO 10545.3	≤ 0,5%	CONFORME IN ACCORDANCE ERFÜLLT CONFORME	ASTM C-373	IN ACCORDANCE
RESISTENZA ALLA FLESSIONE BENDING STRENGTH BIEGEZUGFESTIGKEIT RÉSISTANCE À LA FLEXION	ISO 10545.4	≥ 35N/MM ²	CONFORME IN ACCORDANCE ERFÜLLT CONFORME	ASTM C-648 250 LBS OR GREATER	IN ACCORDANCE
DILATAZIONE TERMICA LINEARE TRA 20° E 100° C LINEAR THERMAL EXPANSION BETWEEN 20° AND 100° C LINEARE WÄRMEAUSENDENUNG ZWISCHEN 20° UND 100° C DILATATION THERMIQUE LINEAIRE ENTRE 20° ET 100° C	ISO 10545.8	SECONDO I DATI DEL COSTRUTTORE ACCORDING TO BUILDER'S SPECIFICATIONS LAUT ANGABEN DES HERSTELLERS SELON LES ELEMENTS DU CONSTRUCTEUR	≈ 7X10 ⁻⁶ C ⁻¹		
RESISTENZA AGLI SBALZI TERMICI THERMAL SHOCK RESISTANCE TEMPERATURWECHSELBESTÄNDIGKEIT RÉSISTANCE AUX ÉCARTS DE TEMPÉRATURE	ISO 10545.9	RICHIESTA REQUEST BITTE DEMANDE	RESISTENTE RESISTANT WIDERSTEHEND RÉSISTANT		
RESISTENZA AL GELO FROST RESISTANCE FROSTBESTÄNDIGKEIT RÉSISTANCE AU GEL	ISO 10545.12	RICHIESTA REQUEST BITTE DEMANDE	RESISTENTE RESISTANT WIDERSTEHEND RÉSISTANT	ASTM C-1026	IN ACCORDANCE
RESISTENZA ALL'ATTACCO CHIMICO RESISTANCE TO CHEMICAL ATTACK BESTÄNDIGKEIT GEGEN CHEMIKALIEN RÉSISTANCE À L'ATTAQUE CHIMIQUE	ISO 10545.13	SECONDO I DATI DEL COSTRUTTORE ACCORDING TO BUILDER'S SPECIFICATIONS LAUT ANGABEN DES HERSTELLERS SELON LES ELEMENTS DU CONSTRUCTEUR	RESISTENTE RESISTANT WIDERSTEHEND RÉSISTANT	ASTM C-650	IN ACCORDANCE
RESISTENZA DEI COLORI ALLA LUCE COLOURS RESISTANCE TO LIGHT LICHTBESTÄNDIGKEIT RÉSISTANCE DES COULEURS À LA LUMIÈRE	DIN 51094	NESSUNA ALTERAZIONE NO ALTERATION KEINE VERÄNDERUNG AUCUNE ALTERATION	CONFORME IN ACCORDANCE ERFÜLLT CONFORME		
RESISTENZA ALLE MACCHIE STAIN RESISTANCE FLECKENFESTIGKEIT RÉSISTANCE AUX TACHES	ISO 10545.14	≥ CLASSE 3 METODO DI PROVA DISPONIBILE TEST METHOD AVAILABLE VERFÜGBARE PRÜFMETHODE METHODE D'ESSAI DISPONIBLE	CONFORME IN ACCORDANCE ERFÜLLT CONFORME		
RESISTENZA ALLO SCIVOLAMENTO SLIPPAGE RESISTANCE RUTSCHSICHERHEIT RÉSISTANCE AU GLISSEMENT	DIN 51130 * DIN 51097 *	9 ≤ R ≤13 A,B,C	NAT LEV BOCCIARDATO R11 NAT LEV BOCCIARDATO A+B+C	ASTM C-1028 * COF ≥ 0,6 DRY ≥ 0,6 WET ANSI * 137.1-2012 DCOF > 0,42 WET	NAT LEV BOCCIARDATO NAT LEV BOCCIARDATO > 0,42 BOCCIARDATO > 0,42
PENDULUM SLIP TEST	BS EN 7976-2*	> 36 DRY > 36 WET	NAT LEV BOCCIARDATO		

*TRATTANDOSI DI NORMATIVE NAZIONALI, I METODI DI PROVA, I REQUISITI E LE CLASSIFICAZIONI VARIANO DA PAESE A PAESE. IL VALORE ATTESO DALLA RESISTENZA ALLO SCIVOLAMENTO DELLA PRODUZIONE DI INDUSTRIE CERAMICHE PIEMME S.P.A., PUÒ VARIARE IN BASE AL LOTTO PRODUTTIVO. SPECIFICA DOCUMENTAZIONE È DISPONIBILE SU RICHIESTA.
TEST METHODS, REQUIREMENTS AND CLASSIFICATIONS DIFFER FROM COUNTRY TO COUNTRY, ACCORDING TO THE NATIONAL REGULATIONS. THE EXPECTED VALUE OF SLIPPAGE RESISTANCE OF PRODUCTS BY INDUSTRIE CERAMICHE PIEMME S.P.A. MAY VARY DEPENDING ON THE PRODUCTION BATCH. SPECIFIC DOCUMENTS ARE AVAILABLE UPON REQUEST.
PRÜFVERFAHREN, ERFORDERNISSE UND KLASSIFIKATIONEN SIND VERSCHIEDEN VON LAND ZU LAND, GEMÄSS DER NATIONALEN VORSCHRIFTEN. DER ERWARTUNGSWERT DER RUTSCHSICHERHEIT DER PRODUKTE VON INDUSTRIE CERAMICHE PIEMME S.P.A. KANN SICH - JE NACH DER PRODUKTIONSPARTIE - VERÄNDERN. SPEZIFISCHE UNTERLAGEN SIND AUF VERLANGEN ZUR VERFÜGUNG.
LES MÉTHODES D'ESSAI, LES RÉQUISITIONS ET LES CLASSIFICATIONS CHANGENT DE PAYS À PAYS, SELON LES RÉGLEMENTATIONS NATIONALES. LA VALEUR ATTENDUE DE RÉSISTANCE AU GLISSEMENT DES PRODUITS DE INDUSTRIE CERAMICHE PIEMME S.P.A. PEUT VARIER EN FONCTION DU LOT DE PRODUCTION. UNE DOCUMENTATION SPÉCIFIQUE EST DISPONIBLE SUR DEMANDE.

ELENCO DELLE SERIE CERTIFICATE E CLASSIFICAZIONI DISPONIBILI A RICHIESTA - LIST OF CERTIFIED SERIES AND CLASSIFICATIONS AVAILABLE UPON REQUEST
LISTE DER GEPRÜFTEN SERIE UND KLASSIFIZIERUNGEN AUF ANFRAGE ERHÄLTICH - LISTE DES SERIES CERTIFIÉES ET DES CLASSEMENTS DISPONIBLES SUR DEMANDE



CERAMICHEPIEMME
FLOOR AND MORE



Norme per la posa e la manutenzione

Installation and maintenance instructions
Verlegung, reiningung und pflege
Guide a la pose et l'entretien

TIPO DI SPORCO	INDICAZIONI PER LA PULIZIA
Birra, Caffè, Gelato, Vino Gomma Pneumatico, Grassi vegetali e animali, Inchiostri, Lampostili Olii Meccanici, Residui di scotch Ollo di lino, PennarelloResine Smalti, Tintura per capelli	Prodotti a Base Alcalina
Cera protettiva anti-abrasione, Depositi calcarei, Macchie di ruggine	Prodotti a Base Acida
Cera di candela, Residui di scotch	Solventi
Per ulteriori informazioni specifiche consultare l'area tecnica sul sito Piemme: www.ceramichepiemme.it	

TYPE OF STAIN	CLEANING SUGGESTIONS
beer, coffee, wine, ice cream vegetable and animal fats, rubber, remains of scotch tape, grease from machines, linseed oil, felt tip pens, paints, inks, hair dye	Alkaline-based detergent
protective anti-abrasion wax, calcareous residuals, rust stains	Acid-based detergent
candle wax, remains of scotch-tape	Solvents
For further specific details please visit the technical area on Piemme website: www.ceramichepiemme.it	

VERSCHMUTZUNGSART	REINIGUNGSHINWEISE
Bier, Wein, Eis, Kaffee Tierische oder pflanzliche Fette Gummi, Kleberbandresten Schmieröl, Tinte, Leilöl, Filzstift, Harz oder Lack, Haarfarbe	Alkalische Reinigungsmittel
Kratzenschutz-Wachs, Kalkablagerunge, Rostflecken	Säure-Reinigungsmittel
Kerzenwachs Kleberbandresten	Lösungsmittel
Weitere Einzelheiten finden Sie in dem technischen Bereich des Piemme website: www.ceramichepiemme.it	

TYPE DE TACHE	NETTOYAGE CONSEIL
Bière, Vin, Glace, Café, Graisses végétales et animales, Encres, Résidus de scotch, Huile de graisse, Hile de lin Crayon feutre Emaux, Teinture pour cheveux, Caoutchouc pour pneus	Détergents à base alcaline
Cire de protection anti abrasion, Dépôts de calcaire, Tache de rouille	Détergents à base d'acide
Cire de bougie Résidus de scotch	Solvant
Pour d'ultérieures informations spécifiques consulter le département technique du site Piemme: www.ceramichepiemme.it	

- Per i prodotti rettificati consigliamo una fuga di 2 mm per un migliore risultato di posa.
- Per una migliore resa estetica Piemme consiglia stuccature colorate in tinta con le piastrelle. Verificare, prima dell'utilizzo, la compatibilità ed idoneità dei riempitivi per fughe con il prodotto ceramico.
- Rimuovere le eccedenze dei riempitivi per fughe quando gli stessi sono ancora freschi.
- Attenersi scrupolosamente alle istruzioni indicate dai produttori dei riempitivi per fughe.
- Per eliminare completamente i residui di posa, che potrebbero compromettere la manutenzione ordinaria e le caratteristiche del prodotto, a posa ultimata, procedere con la pulizia utilizzando prodotti adeguati, a base Acida max 3%, rispettando le indicazioni del produttore. Osservare assolutamente i limiti di tempo indicati nelle istruzioni: un contatto troppo pro lungato con questi prodotti potrebbe provocare il danneggiamento della superficie.
- Gli eventuali aloni che si dovessero presentare dopo la posa di materiali lappati o levigati si potranno facilmente eliminare utilizzando un prodotto idoneo, a base Alcalina.
- Riguardo l'utilizzo di materiali ceramici all'esterno, pure riconfermando l'ingelività dei prodotti Piemme in gres porcellanato, in conformità alle vigenti normative europee EN 14411/ISO 13006-ISO 10545.12, occorre attenersi ad alcune fondamentali norme previste per la posa all'esterno, atte a rendere inattaccabili al gelo i predetti pavimenti. Le condizioni più importanti da rispettare sono: le opportune pendenze, le impermeabilizzazioni, i giunti di dilatazione, e l'uso di idonei materiali per la posa.
- Decorati realizzati con smalti e metalli preziosi é indispensabile proteggere la superficie durante la posa, non utilizzare assolutamente prodotti abrasivi e/o acidi, ma solo acqua e sapone neutro. Il produttore non risponde di eventuali danni a questi preziosi materiali causati da "sfregamenti" durante la posa in opera. Per nessun motivo saranno accettate contestazioni relative a materialeposato.

- For better installation results of rectified products, we suggest 2 mm joint.
- For a better aesthetic finish, Piemme recommends using jointing colours that match the tiles.
- Please check, before using, the compatibility and suitability of grouting material with the ceramic tile.
- Clean away the excess of grouting materials while they are still fresh.
- Follow carefully the instructions pointed out by the producers of tile grouting materials.
- To completely eliminate installation residues, which could negatively affect routine maintenance and product characteristics once installation has terminated, proceed to clean using adequate products, with max. 3% Acid base, following the manufacturer's instructions. Always closely abide by the time limits indicated in the instructions: prolonged contact with these products may cause damage to the surface.
- Any rims that appear after installing lapped or polished materials can be easily eliminated using a suitable Alkaline-based product.
- With regard to the use of ceramic materials outdoors, while once more reiterating that Piemme porcelain stoneware products are frost-proof, in compliance with applicable European standards EN 14411/ISO 13006-ISO 10545.12, a number of fundamental procedures must be followed for outdoor installation, suitable for making the aforementioned floors resistant to frost. The most important aspects are: suitable gradients, waterproofing, expansion joints, and the use of suitable installation materials.
- Decorations made with glazes and precious metals It is most important to protect the surface during installation. Never use abrasive and/or acid products, only water and neutral soap. The manufacturer disclaims liability in case of any damage to these precious materials caused by "rubbing" during installation. Under no circumstances will disputes be accepted relating to the installed material.

- Damit sich eine bessere Verlegung von geschliffenen Produkten ergibt, empfehlen wir eine Fugenbreite von 2 mm.Für ein optisch perfektes Ergebnis empfiehlt Piemme, die Fugen farblich auf die Fliesen abzustimmen.
- Prüfen sie bitte, vor der Verwendung, die Zweckmäßigkeit und die Verträglichkeit des Fugenfüllmittels mit den Keramikfliesen.
- Bitte entfernen sie das überflüssige Fugenfüllmittel wenn es noch frisch ist.
- Folgen sie bitte sorgfältig die von dem Herstellern des Fugenfüllmittels angegebenen Bedienungsvorschriften.
- Zur vollkommenen Entfernung der Verlegerückstände, die die normale Pflege erschweren und die Merkmale des Produkts beeinträchtigen könnten, nach der Verlegung geeignete Reinigungsmittel auf max. 3% Säurebasis verwenden und bei der Reini gung die Hinweise des Herstellers beachten. Die angegebenen Zeiten keinesfalls überschreiten: ein zu lange andauernder Kontakt mit diesen Produkten kann Beschädigungen der Oberfläche verursachen.
- Eventuelle nach der Verlegung von geläppter oder geschliffenem Material sichtbare Schleier lassen sich einfach mit entsprechenden, alkalischen Produkten entfernen.
- Auch wenn die Piemme-Feinsteinzeugprodukte gemäß den europäischen Normen EN 14411/ISO 13006-ISO 10545.12 frostbeständig sind, müssen beim Einsatz keramischer Materialien im Freien einige Grundregeln beachtet werden, damit die Bodenbeläge nicht vom Frost angegriffen werden können. Die wichtigsten Voraussetzungen sind: korrektes Gefälle, Abdichtung, Dehnungsfugen sowie geeignetes Verlegematerial.
- Dekore mit Glasuren und Edelmetallen Während der Verlegung muss die Oberfläche unbedingt abgedeckt werden. Es dürfen keine scheuernden und/oder säurehaltigen Produkte verwendet werden, sondern ausschließlich Wasser und neutrale Seife. Der Hersteller haftet nicht für eventuelle, während der Verlegung durch Abrieb entstandene Schäden an diesen hochwertigen Materialien. Reklamationen von bereits verlegtem Material werden in keinem Fall akzeptiert.

- Pour obtenir le meilleur résultat de pose de produits rectifiés, il est conseillé de réaliser un joint de 2 mm.
- Pour parfaire l'effet esthétique obtenu, Piemme conseille de confectionner des joints de la même couleur que les carreaux.
- Vérifier avant la pose la compatibilité et convenance des remplissages pour joints avec le produit céramique.
- Enlever les surplus des remplissages pour joints alors qu'ils sont encore frais.
- Respecter scrupuleusement les instructions indiquées par les fabricants de remplissages pour joints.
- Pour éliminer complètement tout résidu de pose pouvant gêner l'entretien courant et altérer les caractéristiques du produit, il est conseillé, à la fin de la pose, de procéder au nettoyage du carrelage avec des produits à base acide maximum 3% et de respecter les consignes du fabricant. Suivre impérativement les délais indiqués dans la notice car le contact trop prolongé de ces produits pourrait endommager la surface.
- Pour éliminer facilement la présence éventuelle de cernes après la pose de carreaux rodés ou polis, utiliser un produit à base alcaline.
- Pour ce qui est de la pose à l'extérieur, bien que les produits Piemme en grès cérame soient ingélifs, conformément aux normes européennes EN 14411/ISO 13006-ISO 10545.12, il convient cependant de respecter quelques règles fondamentales de manière à rendre le carrelage inattaquable au gel. Les conditions les plus importantes à remplir sont: le degré d'inclinaison, l'imperméabilisation, les joints de dilatation et l'utilisation de matériaux de pose appropriés.
- Décors réalisés avec des émaux et des métaux précieux Il est indispensable de protéger la surface pendant la pose. N'utiliser en aucun cas des produits abrasifs et/ou acides mais uniquement de l'eau et du savon neutre. La fabricant ne répond pas des dommages éventuels de ces matériaux précieux causés par le frottement pendant la pose. Aucune réclamation, quelle qu'elle soit, concernant le matériau posé ne sera acceptée.

Guida alla Lettura

Reading Guide
Leseanleitung
Guide à la lecture

 Spessore
Thickness
Stärke
Épaisseur

Variazione nelle sfumature di colore
Color shade variations
Variation der Farbnuancen
Variation des nuances de couleur

 Fascia prezzo al metro quadrato
Square meter price range
Quadratmeter preisgruppe
Niveau de prix au mètre carré

 Aspetto uniforme
Uniform apperance
Gleichförmiges aussehen
Aspect uniforme

 Fascia prezzo al pezzo
Price range per piece
Stück preisgruppe
Niveau de prix à la pièce

 Variazione leggera
Slight variation
Leichte variation
Variation légère

 Variazione moderata
Moderate variation
Mäßige variation
Variation modeste

 Variazione casuale
Random variation
Zufällige variation
Variation fortuite

Tutti i formati sono nominali.

All sizes are nominal.

Die Formate sind Nennwerte.

Tous les formats sont nominaux.

Gli spessori riportati in questo catalogo sono nominali e possono variare a seconda dei formati e delle finiture.

The thickness mentioned on this catalogue are nominal and can be different according to the sizes and the finishes.

Die in diesem Katalog angegebenen Fliesenstärke sind nominal und können, je nach Format oder Oberfläche, verschieden sein.

Les épaisseurs reportées sur ce catalogue sont nominales et peuvent varier suivant les formats et les finitions.

I colori e le caratteristiche estetiche dei prodotti sono quanto più possibile vicini a quelli reali, nei limiti consentiti dai processi di stampa.

The colours and appearance features of the products are as close as possible to reality, within the limitation of the printing process.

Die Farben und die ästhetischen Eigenschaften der Produkte entsprechen der Wirklichkeit, innerhalb den von dem Druckverfahren erlaubten Grenzen.

Les couleurs et les caractéristiques esthétiques sont fidèles aux couleurs et caractéristiques réelles dans les limites des procédés d'impression.

Project Management
Mktg Piemme

Print
Ruggeri Grafiche

Finito di stampare a Gennaio 2019
Printed in January 2019

Una storia tutta italiana

Piemme dal 1962, anno della sua fondazione, è protagonista indiscussa del vero Made in Italy, quello fatto di eccellenza, passione e creatività. Oggi tutti i materiali Piemme sono prodotti con tecnologia d'avanguardia come la decorazione digitale inkjet HD, la cottura in forni ad energia pulita a recupero di calore, la rettifica e levigatura in linea "one roof" e la verifica elettronica dello standard qualitativo.

An all-Italian story

Since 1962, the year of its foundation, Piemme has been the undisputed protagonist of real Made in Italy, that which consists of excellence, passion and creativity. Today all Piemme materials are made using cutting-edge technology such as HD inkjet digital decoration, firing in heat-recycling clean-energy kilns, "one roof" grinding and polishing line and electronic quality standard control.

Eine ganz italienische Geschichte

Seit dem Gründungsjahr 1962 ist Piemme ein unangefochtener Hauptakteur des echten Made in Italy: jenem, das auf Exzellenz, Leidenschaft und Kreativität gründet. Alle Piemme Erzeugnisse werden heute unter Einsatz von Spitzentechnologie produziert, wie zum Beispiel mit der digitalen Inkjet-Dekoration, dem Brennen in Öfen mit grüner Energie und Wärmerückgewinnung, dem Schleifen und Polieren in der Linie „unter einem Dach“ sowie der elektronischen Prüfung des Qualitätsniveaus.

Une histoire toute italienne

Depuis 1962, l'année de sa fondation, Piemme est la protagoniste indiscutée du Made in Italy, basé sur l'excellence, la passion et la créativité. Aujourd'hui toutes les phases du cycle de fabrication Piemme sont issues d'une technologie à l'avant-garde comme la décoration numérique inkjet HD, la cuisson dans des fours à énergie propre et à récupération de chaleur, la rectification et le polissage en ligne "one roof" et la vérification électronique de la qualité.

CERAMICHE PIEMME

FLOOR AND MORE

INDUSTRIE CERAMICHE PIEMME S.P.A.
VIA DEL CROCIALE 42/44, 41042 FIORANO (MO) - ITALY
T. +39 0536.849111 - F. +39 0536.849402
WWW.CERAMICHEPIEMME.IT - INFO@CERAMICHEPIEMME.IT